

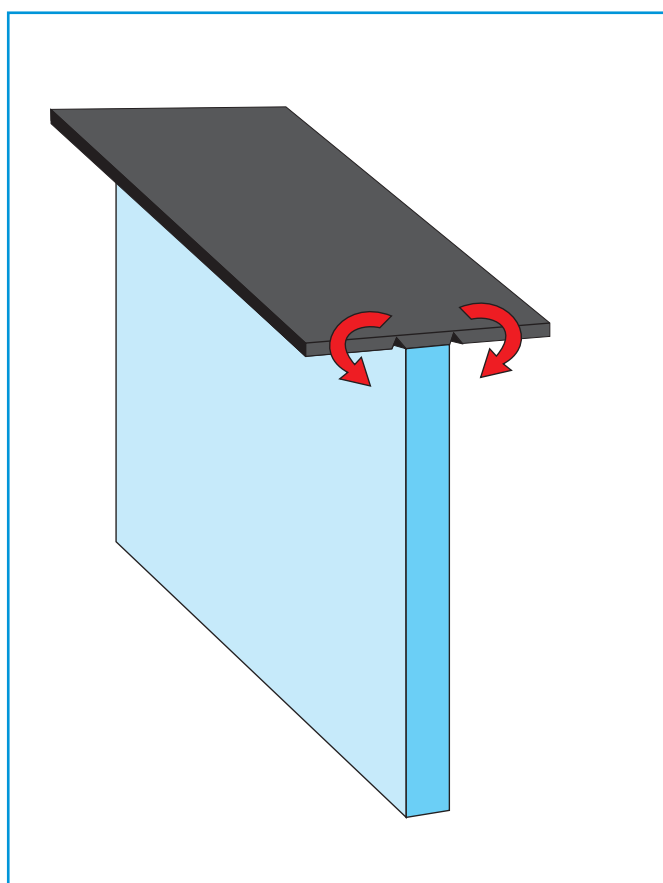

**2**

Clean glass and aluminium profile with alcohol in the zones where gasket will be placed.

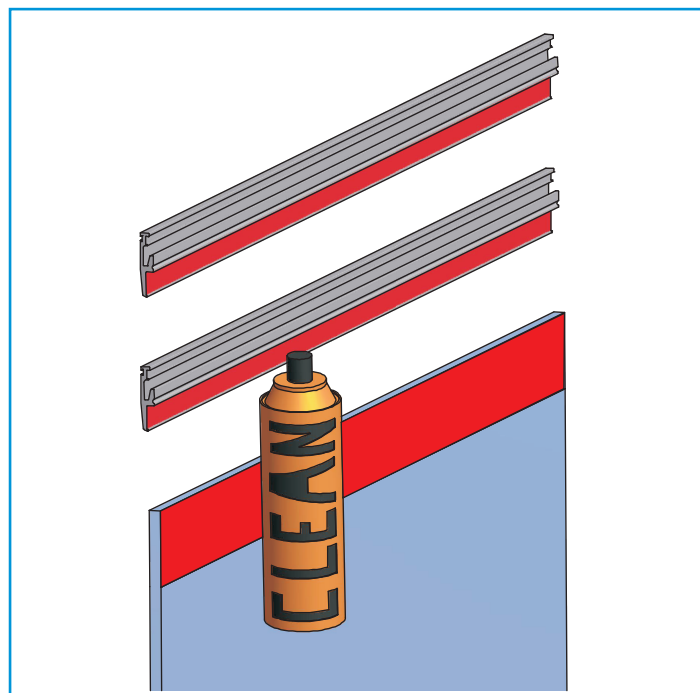

**3**

Take away from the gasket the adhesive protection film beginning from the middle and place the gasket on the glass.

**4**

Place the two profiles LBFL001 and insert the wedge LBFL002.

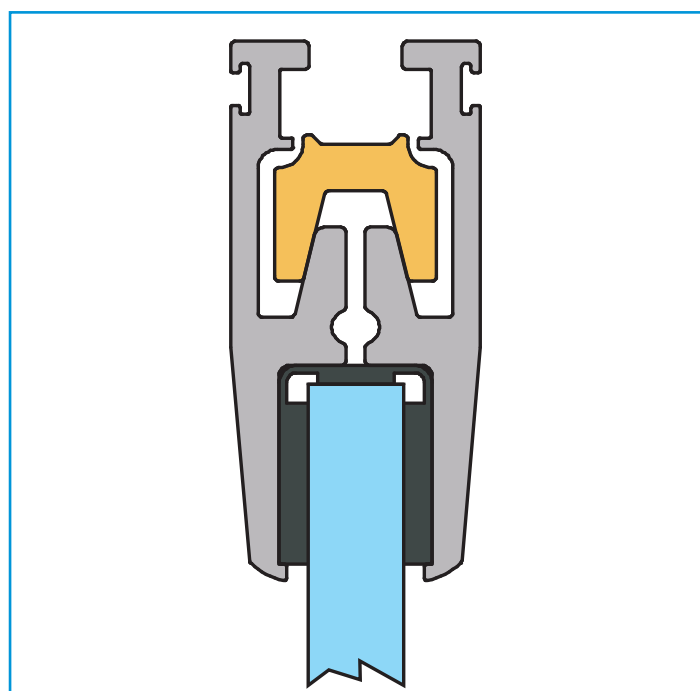

**5**

Place into the proper guide the nuts M8x14 and M8x13.

KIT	M8 13x13	M8 14x14
<b>LBFL101</b>	<b>4</b>	<b>6</b>
<b>LBFL102</b>	<b>4</b>	<b>10</b>
<b>LBFL103</b>	<b>4</b>	<b>14</b>

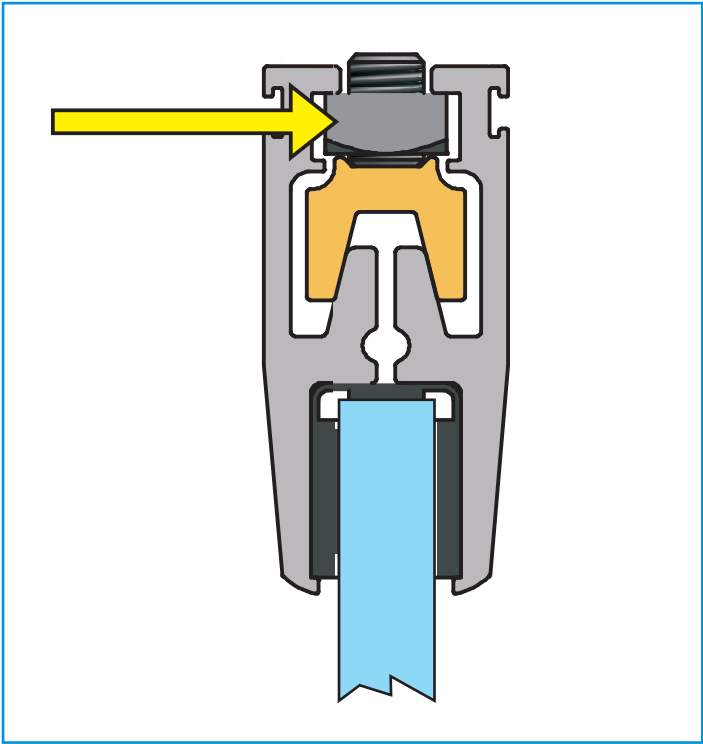

**6**

Space properly the nuts M8 14x14 with a maximum distance of 180mm. Insert M8 13x13 nuts taking care of placing them near door trolleys.

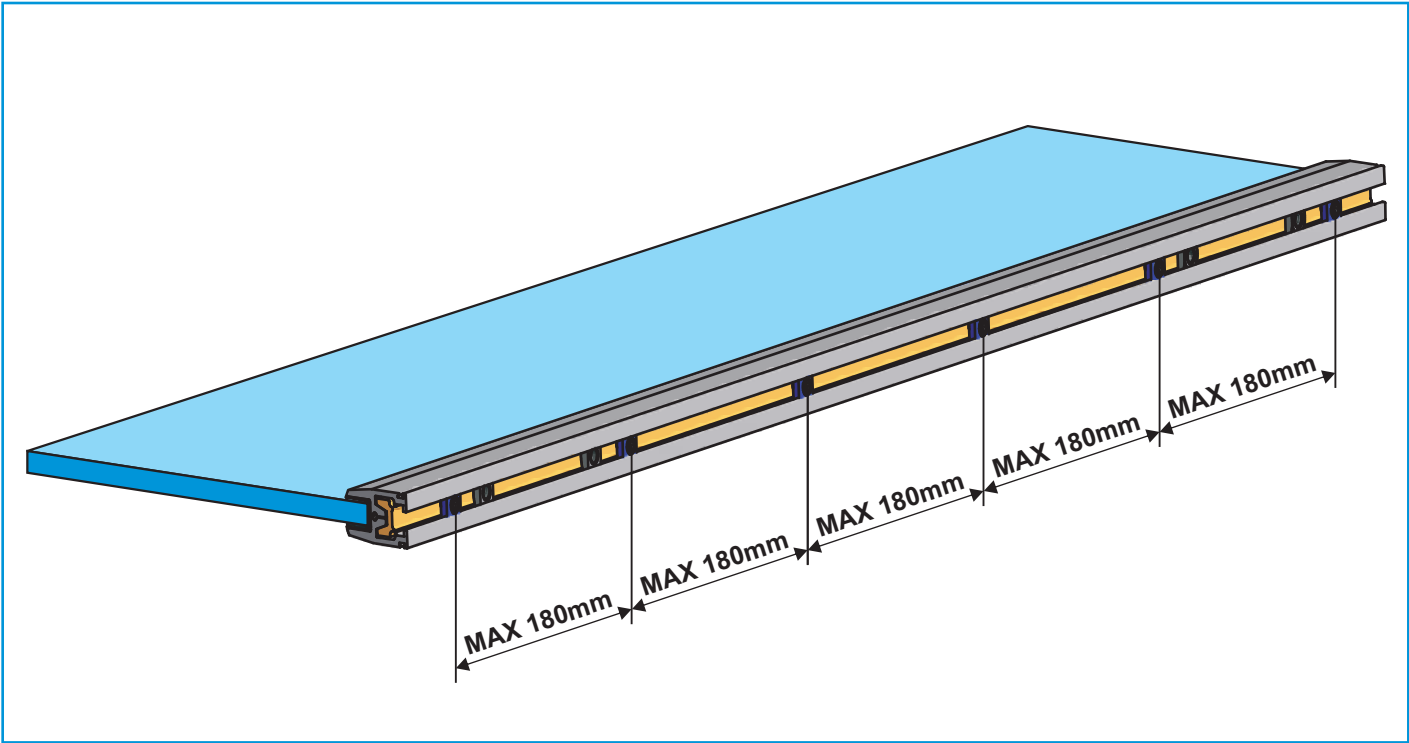

**7**

Screw M8 pins into M8 14x14 nuts, tighten the nuts with a torque of 12Nm.

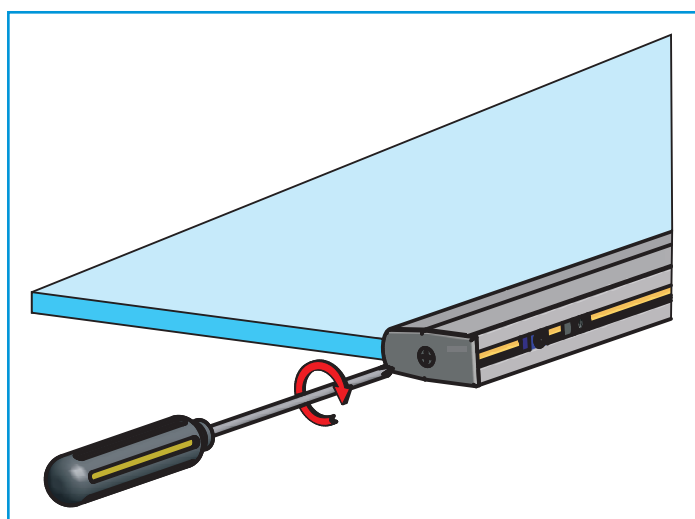
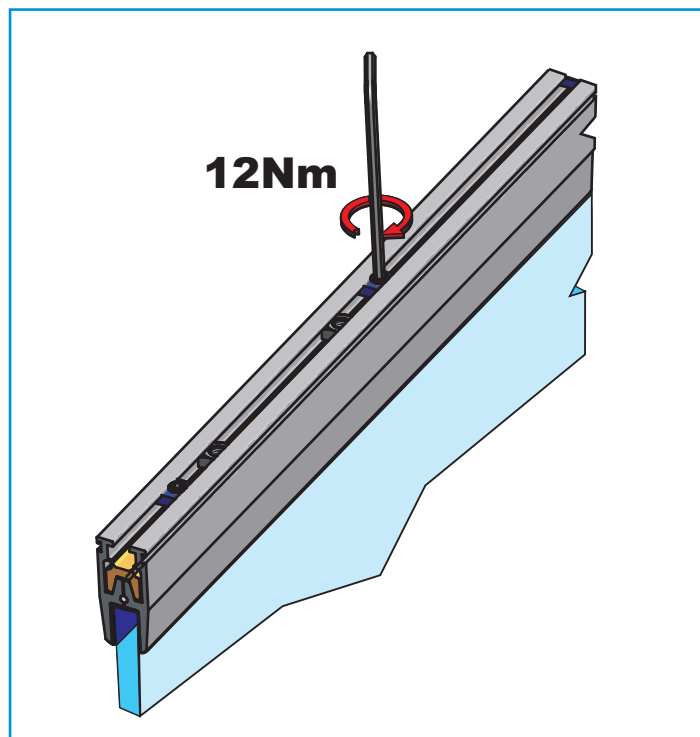

**8**

Place aluminium side caps with flared screws 4,8x16, included.

**9**

Fix leaf connection (provided with the automation) on M8 13x13 nuts.

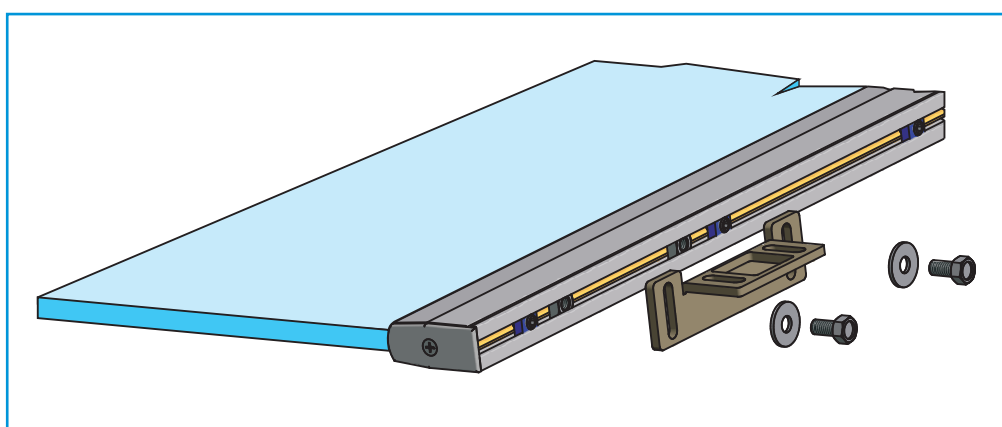

At the end of the installation manually verify if the clamps hold properly the glass.

If the manual verify is ok, it is possible to make the setup control of clamps holding, screws and pins tightening is recommended any six months.